

壓力角20°
M1 模數

GE 標準齒輪(條)沒有做熱處理,如需要熱處理~可指定(GH系)。
GH 齒部表面做的高週波處理、硬度在43~45度,強度及耐磨性會比較好。
GS 伽納也提供SUS303材質,在溼度高的環境能有好的防銹。
Ⓜ SUS無表面處理,僅提供材質[GS]選項。

材質	精度等級	齒面處理
GE S45C 中碳鋼	JIS 4級 (DIN8e25)	精銑
GH S45C 中碳鋼+熱處理		
GS SUS303		

How to order



選擇材質與表面處理

SUS303.....	GS
S45C.....	GE
S45C+熱處理.....	GH
S45C+染黑.....	TB
S45C+鍍硬鉻.....	TC
S45C+無電解鍍.....	TN

庫存品: 交期快、價格低

B型齒寬10有庫存(附最小孔徑~不攻牙)

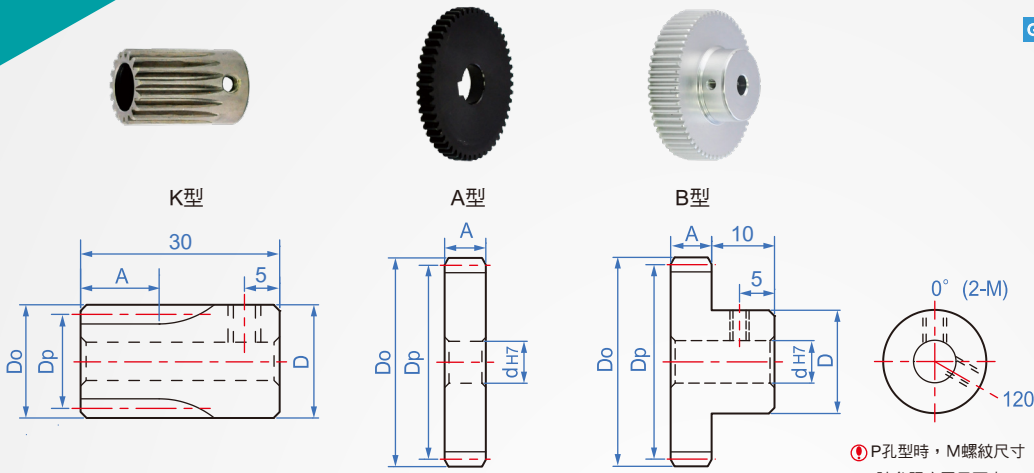

Ⓜ P孔型時, M螺紋尺寸請參照小圖示下方。

齒數	模數	齒面寬度 A	外形	孔形	最小孔徑 d	輪數 D	齒數	分度圓徑 Dp	齒頂 Do
15	M1	10	K (僅適用P孔形)	圓孔徑 	6~	17	15	15	17
16						16	16	18	
17						17	17	19	
18						18	18	20	
19						19	19	21	
20						20	20	22	
21						21	21	23	
22						22	22	24	
23						23	23	25	
24						24	24	26	
25	25	25	27						
26	12	12	A (僅適用圓孔形)	圓孔+攻牙 P (120°) PV (90°) 	8~	23	26	26	28
24						27	27	29	
25						28	28	30	
26						29	29	31	
27						30	30	32	
28						31	31	33	
29						32	32	34	
30						33	33	35	
31						34	34	36	
32						35	35	37	
33	36	36	38						
34	37	37	39						
35	38	38	40						
36	39	39	41						
36	40	40	42						
38	41	41	43						
38	42	42	44						
40	43	43	45						
40	44	44	46						
42	45	45	47						
42	46	46	48						
44	47	47	49						
45	48	48	50						
45	49	49	51						
46	50	50	52						
50	55	55	57						
55	60	60	62						
60	65	65	67						
65	70	70	72						
70	75	75	77						
74	80	80	82						
78	85	85	87						
80	90	90	92						
90	100	100	102						

軸孔徑	攻牙
4~5	M3
6~12	M4
13~30	M5

軸孔徑	kw (Js9)	kh
8~10	3	1.4
NK10	4	1.8
11~12	4	1.8
13~17	5	2.3
18~22	6	2.8
23~30	8	3.3