

壓力角20°
M2 模數

- GE 標準齒輪(條)沒有做熱處理,如需要熱處理~可指定(GH系)。
- GH 齒部表面做的高週波處理、硬度在43~45度,強度及耐磨性會比較好。
- GS 加納也提供SUS303材質,在溼度高的環境能有好的防銹。
Ⓜ SUS無表面處理,僅提供材質(GS)選項。

材質	精度等級	齒面處理
GE S45C 中碳鋼	JIS 4級 (DIN8e25)	精銑
GH S45C 中碳鋼+熱處理		
GS SUS303		

How to order 🗣️



選擇材質與表面處理

SUS303.....	GS
S45C.....	GE
S45C+熱處理.....	GH
S45C+染黑.....	TB
S45C+鍍硬鉻.....	TC
S45C+無電解鍍.....	TN

庫存品: 交期快、價格低

B型齒寬20有庫存(附最小孔徑/不攻牙)

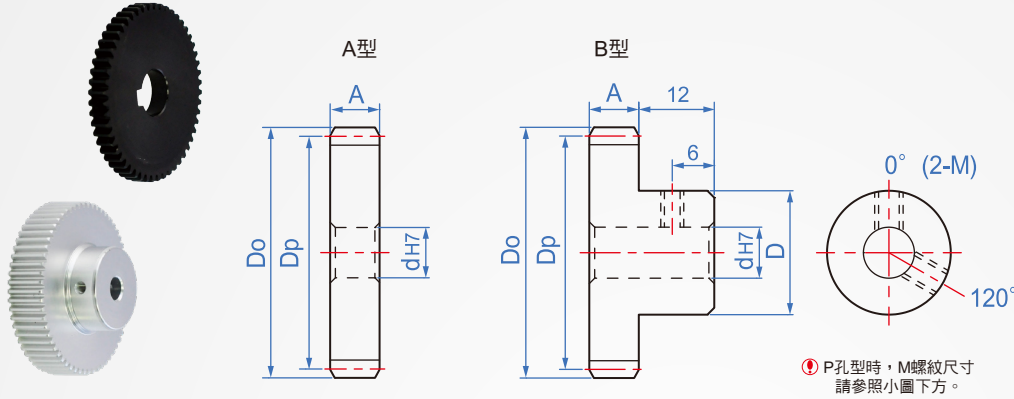

版權所有重製必究

單位: mm									
齒數	模數	齒面寬度 A	外形	孔形	最小孔徑 d	輪數 D	齒數	分度圓徑 Dp	齒頂 Do
15	M2	15	A (僅適用圓孔形)	圓孔徑 	10~	24	15	30	34
16						26	16	32	36
17						28	17	34	38
18						30	18	36	40
19						32	19	38	42
20						34	20	40	44
21						36	21	42	46
22						38	22	44	48
23						40	23	46	50
24						42	24	48	52
25						42	25	50	54
26						45	26	52	56
27						48	27	54	58
28						50	28	56	60
29						50	29	58	62
30		52	30	60	64				
31		20	B	圓孔+攻牙 P (120°) PV (90°) 	12~	54	31	62	66
32						56	32	64	68
33						58	33	66	70
34						60	34	68	72
35						60	35	70	74
36						62	36	72	76
37						65	37	74	78
38						65	38	76	80
39						70	39	78	82
40						70	40	80	84
41						72	41	82	86
42						72	42	84	88
43						75	43	86	90
44						75	44	88	92
45	80					45	90	94	
46	80	46	92	96					
47	85	47	94	98					
48	85	48	96	100					
49	90	49	98	102					
50	90	50	100	104					