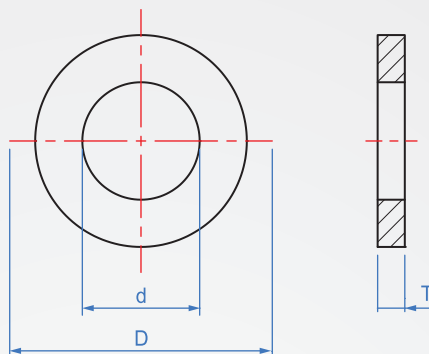

Small OD washer

WS781

Material

SUS304

How to order

WS781 - M3 - 6 - 0.5
 TYPE M OD T

Applicable screw	d		Outer diameter	D		Thickness	T	
	max.	min.		max.	min.		max.	min.
M2	2.34	2.2	4.5	4.5	4.2	0.3	0.35	0.25
M2.5	2.64	2.7	5	5	4.7	0.5	0.55	0.45
M3	3.38	3.2	6	6	5.7	0.5		
M4	4.48	4.3	8	8	7.64	0.5	1.1	0.9
M5	5.48	5.3	9	9	8.64	1		
M6	6.62	6.4	11	11	10.57	1.6	1.8	1.4
M8	8.62	8.4	15	15	14.57	1.6		
M10	10.77	10.5	18	18	17.57	1.6	2.2	1.8
M12	13.27	13	20	20	19.48	2		
M16	17.27	17	28	28	27.48	2.5	2.7	2.3

※ Special specification

Applicable screw	D	T
M3	5	0.5
M4	7	0.5
	8	0.8
M6	10	1
M8	12	1
M10	14	1
M12	20	1