

螺牙套 NL728

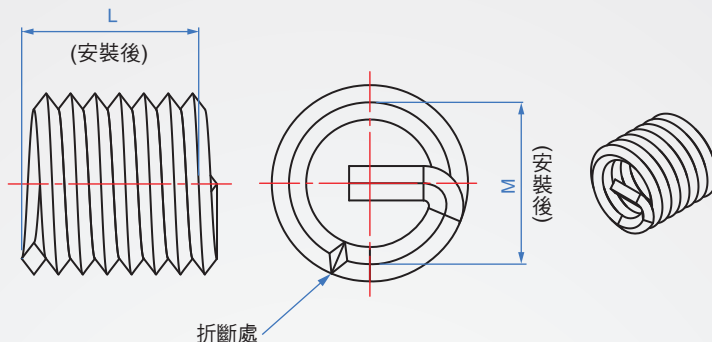

材質	表面處理
SUS304	RC43° ~50°

How to order

NL728 - M2 - []

TYPE M

L 選購

螺牙套..... 1D

絲攻用具(2/3攻)..... TAP

手搖鑽入工具..... TOOL

螺牙套

公制牙		L			攻牙鑽孔尺寸			參考圈數±1/4			價格
M	P	1D	1.5D	2D	適用鑽頭	最小	最大	1D	1.5D	2D	
M2	0.4	2	3	4	2.1	2.1	2.16	3-1/4	5-5/8	8	
M2.5	0.45	2.5	3.8	5	2.6	2.6	2.65	3-3/4	6-1/8	8-1/2	
M3	0.5	3	4.5	6	3.1	3.12	3.2	4	6-5/8	9-1/4	
M4	0.7	4	6	8	4.2	4.17	4.3	3-7/8	6-3/8	8-7/8	
M5	0.8	5	7.5	10	5.2	5.16	5.33	4-3/8	7-1/8	9-1/4	
M6	1	6	9	12	6.3	6.25	6.42	4-1/4	7-1/8	10	
M8	1.25	8	12	16	8.4	8.31	8.52	4-5/8	7-3/8	10-1/4	
M10	1.5	10	15	20	10.5	10.37	10.62	5	8	11	
M12	1.75	12	18	24	12.5	12.43	12.73	5	8-1/4	11-3/8	

螺牙套絲攻用具

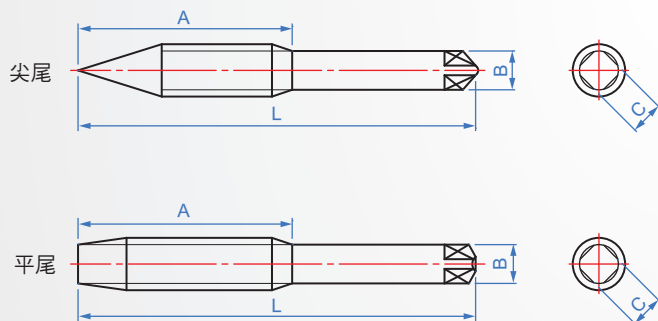

材質：SKH 硬度：61-64HRC

選購絲攻用具

Type	M	適用牙套 M	L	牙長 A	柄徑 B	C
尖尾	M2	M2-0.4	40	15	3	2.5
	M2.5	M2.5-0.45	44	16		
	M3	M3-0.5	48	18	4	3.2
	M4	M4-0.7	60	22		
平尾	M5	M5-0.8	62	24	6	4.5
	M6	M6-1.0	65	26		
	M8	M8-1.25	75	32	7	5.5
	M10	M10-1.5	82	38		
	M12	M12-1.75	90	42	10.5	8

一盒內含兩支(2/3攻)

特性：

- 1.使用螺紋護套可避免機械震動造成螺絲鬆落，導致潰牙。
- 2.用於鋁、鋅、銅等金屬，能有效提升螺紋
- 3.可應用在航太、航海、軍需、武器、戰車、汽車、重工機械等方面。

使用例：

(1)鑽孔

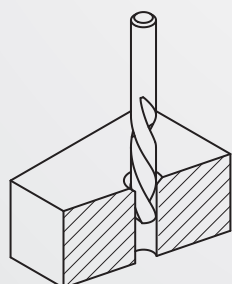

(2)攻牙

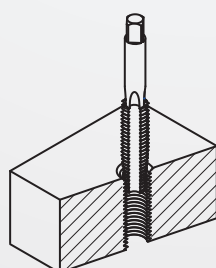

(3)裝入

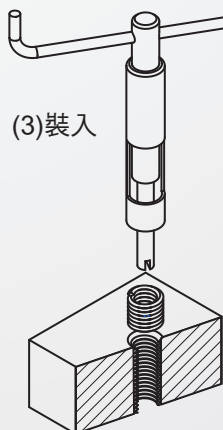

(4)折取

