

Pitch : 10.0mm

AT10

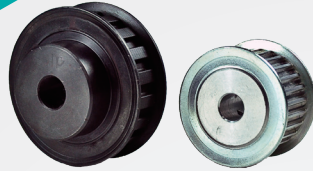

Detailed view A

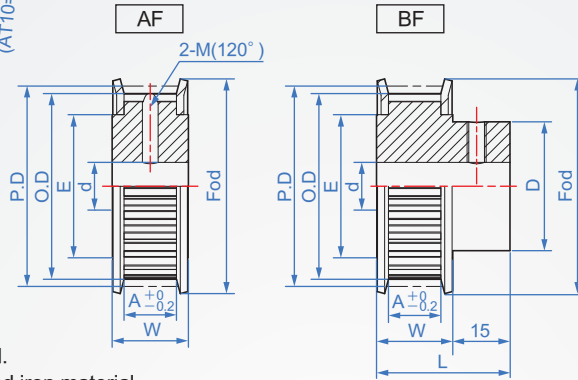
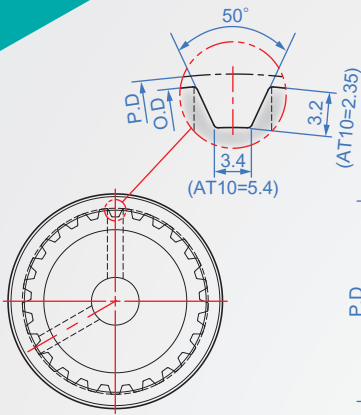

Material : Aluminum A6061+ anodized.
Please contact us if you need iron material.

Belt width	15	20	25	30	40	50
Common size	A=17 W=22 L=37	A=22 W=27 L=42	A=27 W=32 L=47	A=32 W=37 L=52	A=43 W=48 L=63	A=53 W=58 L=73

How to order

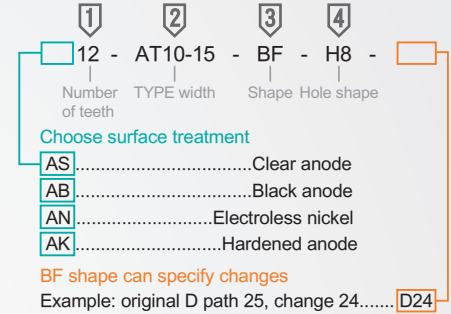

Number of teeth	TYPE width	Shape	Hole shape	Aperture d Processing min.	P.D	O.D	Number of teeth	D	E	Fod				
12				8~	38.2	36.35	12	25	28	40				
13				10~	41.38	39.5	13	27	30	45				
14					44.56	42.7	14	32	34	47				
15					47.75	45.9	15	33	38	53				
16					50.93	49.05	16	35	40	55				
17					54.11	52.25	17		44	58				
18				12~	57.3	55.45	18	40	43	60				
19					60.48	58.6	19		45	65				
20					63.66	61.8	20		47	52.5	67.5			
21					66.85	65	21	55		75				
22	AT10-15				70.03	68.15	22	60		60	80			
23					73.21	71.35	23			83				
24					14~	76.39	74.55	24	60	65	85			
25						79.58	77.7	25				63	70	90
26	AT10-20					82.76	80.9	26	70	75	95			
27						85.94	84.1	27						
28				16~		89.13	87.25	28	70	75	95			
29					92.31	90.45	29	73				80	100	
30	AT10-25	AF			95.49	93.65	30		75	84	104			
31					98.68	96.8	31							80
32					101.86	100	32	85	90	110				
33	AT10-30	BF			105.04	103.2	33				87	95	115	
34					108.23	106.4	34							90
35					111.41	109.55	35	95	102	123				
36	AT10-40				114.59	112.75	36				97	105	125	
37					117.77	115.9	37	100	110	128				
38				120.96	119.1	38	115				140	146		
39				124.14	122.3	39							125	152
40	(AT10-50)			127.32	125.45	40	128	160	165					
41				130.51	128.65	41				130	165	165		
42				133.69	131.85	42	135	170	175					
43				136.87	135	43				140	175	180		
44				140.06	138.2	44	145	180	185					
45				143.24	141.4	45				150	185	190		
46				146.42	144.55	46	155	190	195					
47				149.61	147.75	47				160	195	200		
48				152.79	150.95	48	165	200	205					
49				155.97	154.1	49				170	205	210		
50				159.15	157.3	50	175	210	215					

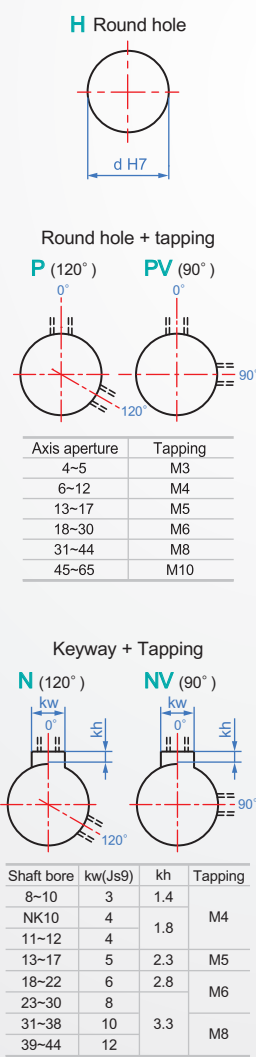

Copyright © CHENA INDUSTRIAL CO.,LTD ALL RIGHTS RESERVED.