

Over Heavy Duty - Active Wheel A

# AM892

Steel plate long

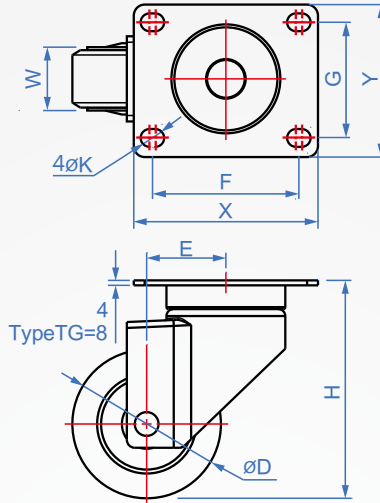

Type	ontology	Surface treatment	Wheel	Bearing
TH	Steel	electric black	Nylon	Double ball
TB			MC nylon	
WB		white zinc plated	MC nylon	
TG				

### How to order

AM892 - TH - 65  
TYPE Kind D

Allowable load (kgf)	Kind	Wheel diameter		W	H	E	Chassis		Mounting holes		
		D	Inch				X	Y	F	G	K
400	TH (heavy load)	65	2.5"	45	95	34	108	85	80	60	11
450		75	3"		105						
600	TB (overweight)	*55	2.2"	45	81	25	108	85	80	60	11
700		65	2.5"		102						
800		75	3"		107						
700	WB (extremely heavy) double wheel	65	2.5"	44	102	25	108	85	80	60	11
800		75	3"		107						
1000	TG (load)	80	3"	55	130	42	140	110	107	77	12

\*TB-55 surface treatment white zinc plating

1kgf=9.8N