

精密固鎖螺帽

MR779

徑向3點鎖定

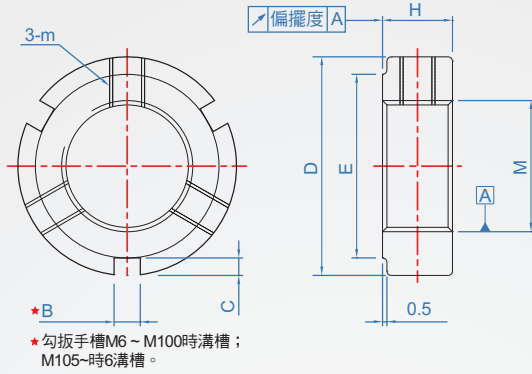

材質	表面處理	螺紋精度	平面偏擺度	附屬品
SUS304	去脂		0.005mm	
SCM440 HRC28~32	染黑	ISO 4H 等級	0.005mm (標準)	前端含銅 止付螺絲
			0.002mm (高級)	

※螺紋方向為右螺牙，如需左螺牙可另洽詢各區窗口

How to order

MR779 - M6 - 0.5 -

TYPE 螺紋 Pitch

選擇材質與偏擺度

標準0.005 .....  SUS

標準0.005 .....

高級0.002 .....  G

版權所有 重製必究

螺紋	Pitch	標準 (0.005mm)		高級 (0.002mm)		H	B	C	止付螺絲	
		D	E	D	E				m	鬆脫力矩
		單位: mm								
M6	0.5									
M8	0.75	16	11	16	11					
M8	1									
M10	0.75	18	13	18	13	8	3-3		M4	2.2 (max. Nm)
M10										
M12		20	18	24	19					
M15	1	25	21	28	23			2		
M17		28	23	32	27					
M20		32	27	35	30	10	3-4		M5	4.8 (max. Nm)
M20										
M25		38	33	42	36					
M30		45	40	48	43	12	3-5			
M35	1.5	52	47	53	48					
M40		58	52	58	52				M6	8 (max. Nm)
M45		65	59	65	59	14	3-6	2.5		
M50		70	64	70	64					
M55		75	68	75	68					
M60		80	73	80	73	16	3-7	3		
M65		85	78	85	78					
M70		92	84	92	84					
M75		98	90	98	90					
M80		105	96	105	96	18	3-8	3.5		
M85		112	104	112	104					
M90		118	108	118	108					
M95		123	113	123	113					
M100	2	128	118	128	118	20	3-10	4	M8	19 (max. Nm)
M105		137	125	137	125		6-10			
M110		145	132	145	132					
M115		150	137	150	137					
M120		155	142	155	142	24				
M125		160	147	160	147					
M130		165	152	165	152					
M135		175	160	175	160					
M140		180	165	180	165					
M145		190	175	190	175	26	6-12	5		
M150		195	180	195	180					
M155		200		200						
M160		210	190		190	28			M10	36 (max. Nm)
M165		215	195							
M170	3	220	200	220	200					
M180		230	210	230	210					
M190		240	220	240	220	30				
M200		250	230	250	230					