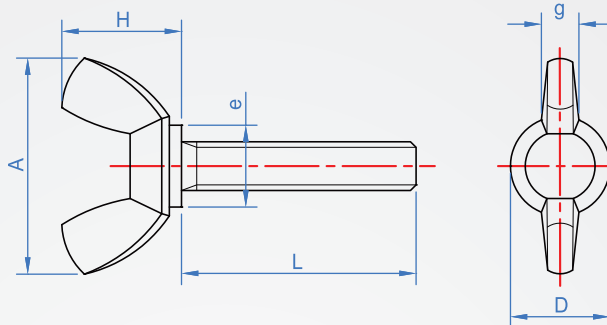

Wing screw

WA711

Material

SUS304

International norm DIN316

How to order

WA711 - M3 - 10
 | | |
 TYPE M L

Unit: mm

M	pitch	L										A max.	D	e	g	H max.	
M3	0.5	6	8	10	12	16	20					18.5	7.8	6	2	8.8	
M4	0.7		8	10	12	16	20	25	30			21	9.6	7	2.5	9.6	
M5	0.8		8	10	12	16	20	25	30	35		22	10.5	8	2.6	10.5	
M6	1.0			10	12	16	20	25	30	35	40	26.8	12.9	10.5	3	12.9	
M8	1.25				12	16	20	25	30	35	40	50	30.3	14.8	12	3.3	14.8
M10	1.5						20	25	30	35	40	50	35.3	17.3	14	4	17.3

Che Na

FAX 886-2688-3177

info@chena.com.tw

886-22688-3188
886-2688-3881~3No.21, Guangrong St. Shulin Dist.,
New Taipei City 238 Taiwan (R.O.C.)