

Ultra-low bow  
**ZC734**  
 Hexagon socket

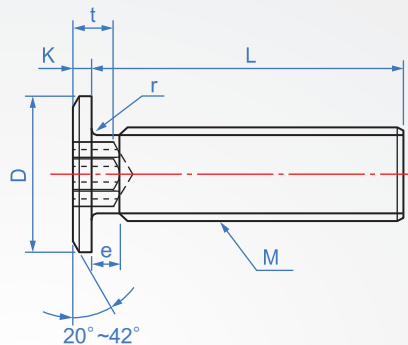
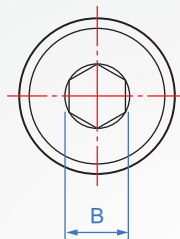

Material	Intensity differentiation
SUS304	A2-50

How to order

ZC734 - M2 - 10  
 TYPE M L

													unit:mm							
M	Pitch		L										D	B	K	t	e	r	Tightening torque N · m	Tensile Strength N/mm <sup>2</sup>
	Coarse teeth																			
M2	0.4	3	4	5	6	8	10						4		0.5	1.2		0.16	200	
M2.5	0.45	3	4	5	6	8	10						5	1.27	0.6	1.5	1.2	0.1		0.35
M3	0.5		4	5	6	8	10	12	16				6	1.5	0.8	2	1.4	0.6		
M4	0.7			5	6	8	10	12	16	20	25		8	2	0.9	2.5	1.5	0.2	1.1	350
M5	0.8				6	8	10	12	16	20	25		9	2.5	1	3	1.8	2.2		
M6	1					8	10	12	16	20	25	30	10	3	1.2	4	2.2	0.25	5	