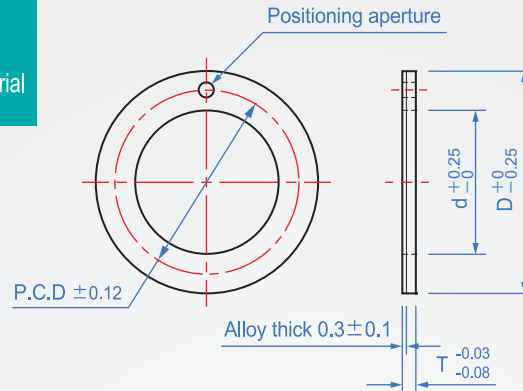

Washer

JZ259-B Composite material

Material

Teflon-Lead Impregnation
+Sintered bronze
(Metal iron tinning)

Heat resistance

-200°C~+280°C

How to order

JZ259 - 12-B
 TYPE No.



Unit : mm

No.	Applicable sleeve inner diameter	d	D	T	Positioning hole size		
					Diameter	Tolerance value	P.C.D
6-B	6	8	16	1.5	1	+0.3 +0.1	12
8-B	8	10	18				14
10-B	10	12	24		1.5	+0.375 +0.125	18
12-B	12	14	26				20
14-B	14	16	30				23
16-B	15、16	18	32		3	+0.375 +0.125	25
18-B	18	20	36				28
20-B	20	22	38				30
22-B	22	24	42				33
25-B	25	28	48		4		38